



19"

λ



Brightness	350 cd/m <sup>2</sup>
Contrast	1000 : 1
Resolution	1280 x 1024
Refresh-Rate	8ms
Viewing Angle	178°/178°
CCFL-Lifetime	50.000 H
H-Freq.	12-100 kHz
V-Freq.	10-200 Hz
Sync.	SoG, H/V, Composite, SoR, SoB
Active Area	(376,3x301,06)mm
Ratio	5:4
Colours	16,7 Billion
Interlace	OK
SoG<0,3 V	OK
SoG adj.	OK
Video	Option
Input	HD 15 Sub / 5x BNC
VESA-Mount	75mm and 100mm

---

# Lambda Electronic GmbH

Emser Str. 328 – 56076 Koblenz

---

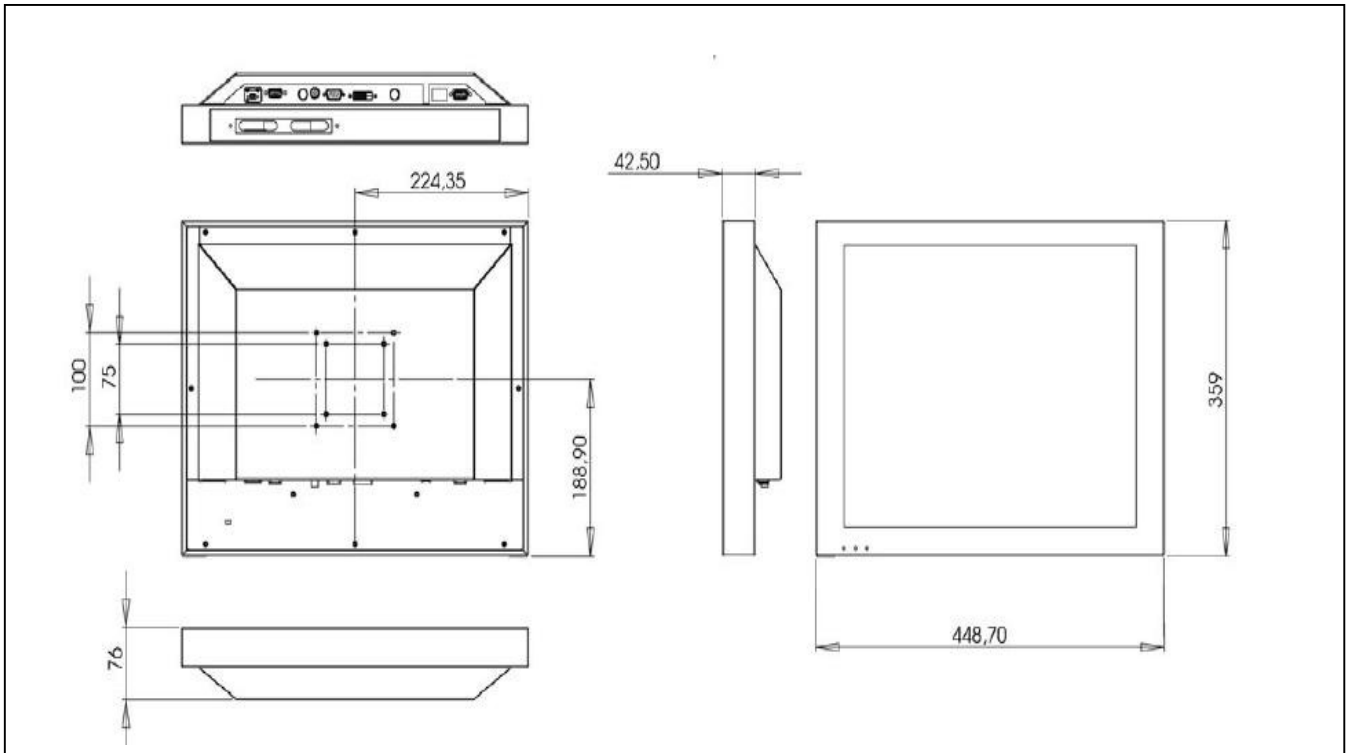

*Have a look also to following products !*

*12,1" - 15" - 17" - 20,1" - 23" - 24" - 32" - 37" - 42" - 47"*

Phone : +49 (0)2 61 – 97 35 74 93

eMail: [sales@lambda-electronic.de](mailto:sales@lambda-electronic.de)  
Web: [www.lambda-electronic.de](http://www.lambda-electronic.de)